

Hydraulics for Vortex Pumps T

The vortex impeller is an «open» impeller whereby power transfer to the fluid being transported is comparable to the principle of a hydraulic coupling. Egger, the pioneer in vortex impellers, has rigorously optimized their special hydraulic properties to today's industry needs. Various impeller variations have resulted from this, offering optimal conditions for each application.

Insensitivity to abrasion – gentle pumping

As a result of the Turo® System, the major proportion (85%) of the fluid being pumped is transported directly from the primary vortex to the pressure connection. Only 15% of the fluid being pumped comes in contact with the impeller through the secondary vortex. Sealing gaps which could wear during solids handling and cause grinding effects are not present in our construction. That reduces the abrasive attack to a minimum and sensitive structures in the material to be conveyed such as crystals, bacterial flakes or algae remain largely unaffected. Any potential wear on the impeller always develops symmetrically; therefore the balance and thus the quiet running of the pump remain assured. The output will only drop significantly with an almost completely abraded impeller.

Higher, longer-lasting efficiency through optimal flow geometries

One component of the Turo® System is the patented axial spiral in the casing. It means, Egger specially applies coordinated casing geometries to the vortex impeller. This optimal interaction between impeller and casing confers to Egger Turo® Pumps the high discharge heads and efficiency uniquely achievable by vortex impeller pumps. Because of their insensitivity to wear, efficiency levels are sustained, even over long periods of time.

Great freedom from clogging by particles and fibers – open spherical channel

This feature is achieved by the completely recessed impeller. Solid objects up to the diameter of the pressure outlet and long fibrous materials do not cause any malfunctions. There are no

the shaft, regardless of whether the pump is used for minimal, optimal or maximal production volumes – a further advantage compared to closed impeller shapes. Together with the highly balanced nature of the impeller, this guarantees quiet operation of the pump.

Non-clogging, safe delivery rate due to the recessed impeller and a patented axial spiral

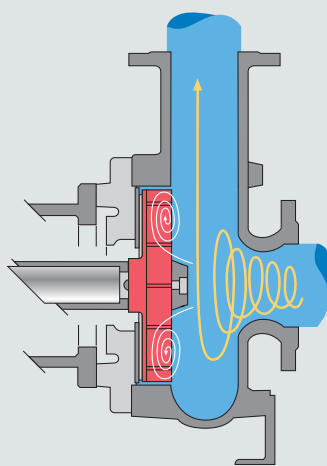

Totally recessed impeller



Patented axial spiral

channels that the solids have to pass through nor are there any radial gaps between the pressure and suction sides that could be clogged by fibers and otherwise obstruct the pump.

Quiet operation from the minimum to the maximum output

Turo® vortex impellers transfer only minimal, near-constant radial forces to

Impeller variations

The Turo® TA impeller is suitable for pumping municipal raw wastewater with high proportions of textiles, who tend to clog. It is hydraulically optimized for this requirement and fully integrated into our Turo® Vortex pump's modular system.

1101.en - 05.2013

Headquarter

Emile Egger & Cie SA
Route de Neuchâtel 36
2088 Cressier NE (Switzerland)
Phone +41 (0)32 758 71 11
Fax +41 (0)32 757 22 90
info@eggerpumps.com

Offices and representatives countries

Belgium	Italy	Switzerland
China	Netherlands	USA
Germany	Austria	
France	Poland	
Great Britain	Sweden	
India	Spain	



Further information can be found on:
www.eggerpumps.com

Hydraulics for process pumps EO/EOS

The semi-open radial impeller with special profile is a logical development of the original Egger impeller, which brought about the founding of the firm in 1947. The EO and EOS impeller family is distinguished most significantly by their number of blades; their hydraulic properties are virtually identical.

Transport of fluids with high gas content – high suction capability

Ordinary radial impellers are known for their limited transport of gas content which results in a drastic reduction of output to the point where delivery stops altogether. Since its founding in 1947, Egger has focussed on this problem. Our special blade geometry guarantees the delivery of gas contents up to 25%, as has been proven in numerous reactor loop installations in the chemical industry. This hydraulic family exhibits low $NPSH_R$ values.

Higher, longer-lasting efficiency through adjustable impeller openings – also under conditions of wear

Semi-open impellers have a fixed wear plate opposite them. The gap between them is critical for the performance data (Q, H, η). For abrasive fluids, the gap gets bigger and bigger and causes a reduction in the nominal pump values. The pumps in the EO and EOS families are equipped with a wear plate that can be adjusted from the outside and with which one can reset the impeller gap back to its original size. Thus, the specified original delivery characteristic values can be restored and a replacement can be usually omitted in the longer term. As an alternative, under conditions of high wear, the casing cover can also be equipped with a replaceable wear insert.

Impeller models EOS: For an excellent freedom from clogging by particles and fibres

The triple-bladed EOS-impeller has a larger, open spherical channel than the EO-impeller and is used primarily for slurries and suspensions of larger

High efficiency pumps for homogeneous slurries containing high concentrations of solids

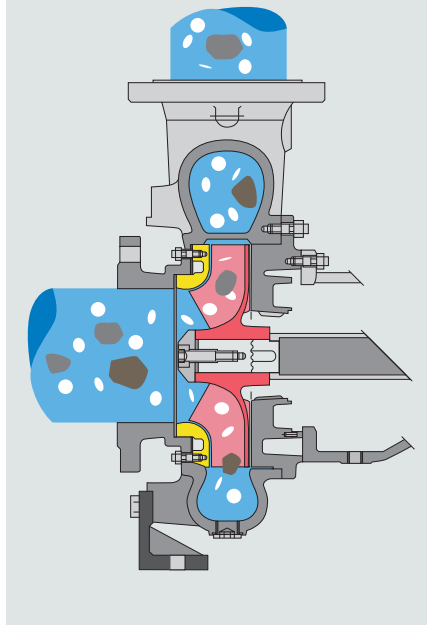

solids. The blade leading edge and the opposing wear plate have special designs that make it possible to transport even long-fibre components, such as occur in wastewater.

Transport of high consistency paper pulp

Egger has been known for decades for pulp pumps in the pulp and paper industry. Fibres, high air content, etc. – these are all everyday occurrences that are very challenging. The process pump production series EO/EOS with their special blade geometries guarantees even for this case the safe delivery of consistencies as high as 8% bone dry.

Multi-purpose applicability

Gathering the large number of specific hydraulic properties in a hydraulic system and pairing them with sound construction make the EO/EOS production series genuine process pumps that are valued as such by our clients all over the world. Egger process pumps are suited for a wide range of abrasive, corrosive and viscous fluids and even multiphase suspensions, containing solids and high gas content.

The process pump range is also available in a high pressure and high temperature execution.

1102.en - 06.2013

Headquarter

Emile Egger & Cie SA
Route de Neuchâtel 36
2088 Cressier NE (Switzerland)
Phone +41 (0)32 758 71 11
Fax +41 (0)32 757 22 90
info@eggerpumps.com

Offices and representatives countries

Belgium	Italy	Switzerland
China	Netherlands	USA
Germany	Austria	
France	Poland	
Great Britain	Sweden	
India	Spain	



Further information can be found on:
www.eggerpumps.com